

PA system

Main

Console: MIDAS SIENA 400
 Full range speaker: RCF TT25 × 2(メイン), TT22 × 2(インフィル)
 Sub woofer: RCF TTS28 × 2
 Full range amplifier: LAB, GRUPPEN C68:4
 Sub woofer amplifier: QSC PL236 × 2
 Processor: RCF DX4008
 Graphic equalizer: KLARK-TEKNIK DN360

Monitor

Speaker: EV TX1152 FM × 5
 YAMAHA S1151V × 2(SIDE)
 Amplifier: QCS POWER LIGHT1.8 × 3
 Graphic equalizer: YAMAHA Q2031A × 1
 YAMAHA Q2031B × 2

Effector

Gate dbx 274(4ch)
 Comp BEHRINGER MDX 2100 × 4
 MALTI YAMAHA SPX 2000 × 2
 Delay Roland SDE-3000

Microphone

Dynamic: SHURE SM58LCE × 6
 SHURE SM57LCE × 6
 SHURE BETA58A × 5
 SHURE BETA57A
 SHURE BETA52
 SENNHEISER e604 × 2
 Condenser: AKG C-391 × 3
 Direct box: BOSS DI-1 × 1
 CONTRYMAN TYPE85 × 5

Microphone stand 210 × 9 259 × 11 200 × 1

Audio hardware

CD deck: TASCAM CD-RW900SL x 2
 DVD deck: TASCAM DV-D01U
 TOSHIBA DBR-Z110
 Projector: EPSON EB-S04/screen:100inch

Amplifier etc

Guitar AMP: Roland JC-120J
 Fender Twin Reverb BLK panel re issue
 (Head): Marshall 1959 100w re issue 4input
 (Speaker): Marshall 1960 BX
 Marshall 2000 TSL-100(☆)
 Bass AMP(Head): GALLIEN-KRUEGER 800RB
 (Speaker): AMPEG SVT 810E
 Drums: YAMAHA YD-9000
 BD/22", TT/10", 12", 13", 16", SNARE/14"
 Cymbals: Zildjan
 Clash/ROCK CLASH:16", 18"
 Ride/ROCK RIDE:21"
 Hi-hat/New Beat Hihats:14"
 Keyboard: YAMAHA P115(☆)

DJ

DJ Mixer: PIONEER DJM-700(☆)
 Turntable: Technics SL-1200MK3 × 2
 CDJ: PIONEER CDJ-1000 MK3 × 2(☆)

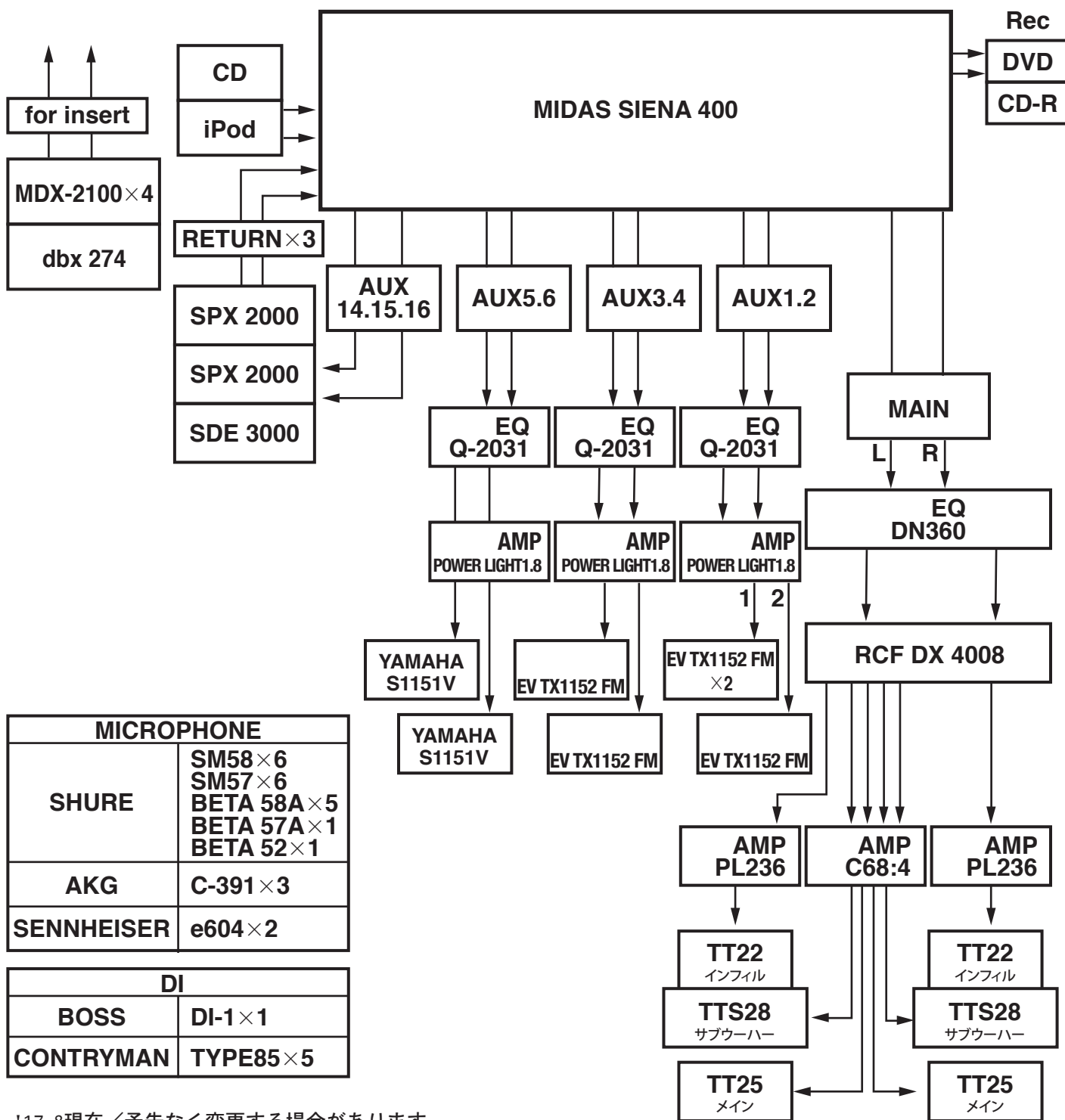

MICROPHONE	
SHURE	SM58×6
	SM57×6
	BETA 58A×5
	BETA 57A×1
	BETA 52×1
AKG	C-391×3
SENNHEISER	e604×2

DI	
BOSS	DI-1×1
CONTRYMAN	TYPE85×5

*17.8現在/予告なく変更する場合があります。

